



GigE DPI

Digital Program Insertion via Gigabit Ethernet



Overview

ARRIS extends their industry leadership in digital advertising insertion with Gigabit Ethernet Digital Program Insertion (GigE DPI) Servers in configurations from 240 channels to an industry-record 1,920 channels per server. The highly scalable GigE DPI Servers allow cable operators and telcos to extend the bandwidth and cost advantages of GigE to ad insertion. Operators can use these highly scalable GigE DPI servers to convert from analog ad insertion to digital-into-digital insertion at a dramatically lower cost per channel than with previous insertion techniques.

GigE DPI Servers are managed by The ARRIS SkyVision management software (version 3.0+). SkyVision manages up to 3,000 ad insertion channels and enables GigE digital insertion, DVB-ASI digital insertion, and analog insertion to be used concurrently in the same system. Ad management techniques are the same across all insertion types, keeping adaptability and efficiency high and staffing requirements low.

Features

- 240-, 480-, 960-, and 1,920-channel digital program insertion servers
- SD and HD ad insertion via GigE
- High channel concentration provides low cost per digital channel
- Redundancy features ensure high availability
- Small footprint delivers up to 35 channels per RU
- Compatible with the ARRIS SkyVision management software

- **Highly scalable:** Available in 240-channel, 480-channel, 960-channel, and 1,920-channel configurations. Multiple configurations can be mixed in one system to meet specific needs.
- **Compatible with Industry Standards:** SCTE30/35 compliant. Designed for use in a Digital Simulcast network environment.
- **Flexible:** SD and HD MPEG-2 video streaming via GigE—copper or optical
- **High Availability:** Each server contains a high degree of built-in redundancy. Automated system-level redundancy options are available.

GIG E DPI Digital Program Insertion via Gigabit Ethernet

- **Compact Size:** 20 to 35 channels per standard rack unit conserve previous headend floor space and physical resources.
- **Reliable:** Based on UNIX for robustness and virus resistance

GigE DPI Servers

- **240-Channel:** Inserts up to 240 concurrent SD channels over two GigE streaming ports—copper or optical. 12 rack units (RUs)* deliver 20 channels/RU.
- **480-Channel:** Inserts up to 480 concurrent SD channels over 4 GigE streaming ports—copper or optical. 17 RUs* deliver 28 channels/RU.
- **960-Channel:** Inserts up to 960 concurrent SD channels over 8 GigE streaming ports—copper or optical. 27 RUs* deliver 35 channels/RU.
- **1,920-Channel:** Inserts up to 1,920 concurrent SD channels over 16 GigE streaming ports—copper or optical. 54 RUs* deliver 35 channels/RU.

HD and SD from the Same Server

An HD channel of ad insertion is created from five 3.75 Mbps SD channels. Each GigE streaming port on the GigE DPI Servers supports up to 23 concurrent HD channels. Channels not used for HD are available as SD channels. Example: A 480-channel GigE DPI Server is used to deliver 32 HD channels and 300 SD channels. The HD channels are created by merging the streaming resources of 160 SD channels. After the HD channels are provisioned, capacity remains for 320 SD channels. In our example, 300 SD channels are supported in addition to 32 HD channels, with 20 SD channels unallocated and available for channel expansion.

*Not including external LAN equipment, power strips, etc.

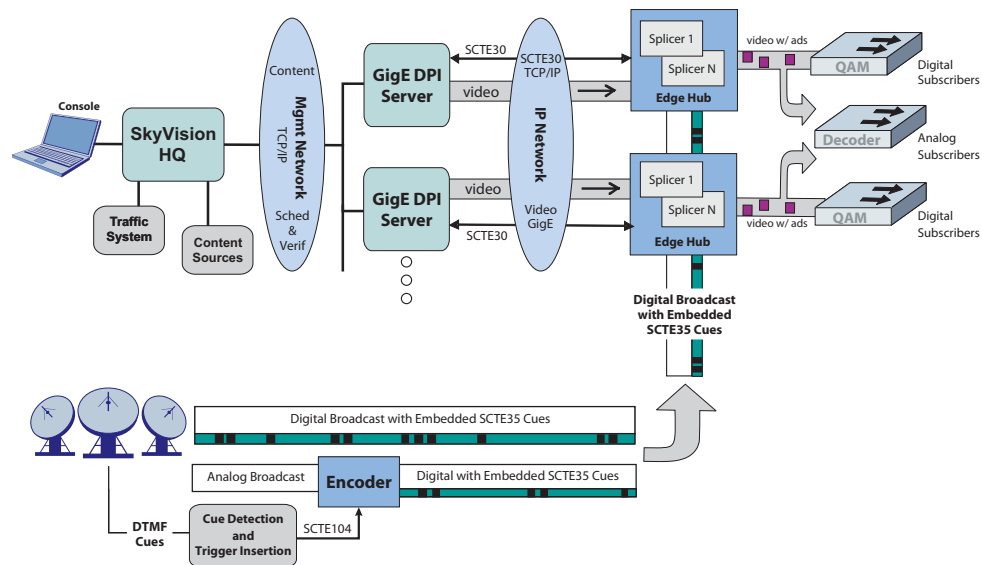

The capabilities, system requirements and/or compatibility with third-party products described herein are subject to change without notice. ARRIS, the ARRIS logo, C3™, C4™, CableEdge™, Cadant™, C-COR™, CHP Max™, Cornerstone™, CXM™, D5™, Digicon™, Flex Max™, Keystone™, MONARCH™, n5™, nABLE™, NSM™, nVision™, PLEXIS™, Regal™, ServAssure™, TeleWire Supply™, Touchstone™, VoiceAssure™, and WorkAssure™ are all trademarks of ARRIS Group, Inc. Other trademarks and trade names may be used in this document to refer to either the entities claiming the marks and the names of their products. ARRIS disclaims proprietary interest in the marks and names of others. © Copyright 2008 ARRIS Group, Inc. All rights reserved. Reproduction in any manner whatsoever without the express written permission of ARRIS Group, Inc. is strictly forbidden. For more information, contact ARRIS.