



1 GHz Extended Linearized Forward Transmitters

CHP-GFX-DXL

C-COR® CHP Max5000

- 1GHz bandwidth increasing forward capacity by 16%
- Analog linearization out to 870MHz to support global channel plans
- Unlock narrowcast bandwidth to accelerate deployment of advanced services
- Universal local or remote management through a Craft interface or SNMP HMS-compliant interface
- Investment protection through 2RU footprint



ARRIS C-COR CHP Max5000 1GHz Forward Path Transmitter with analog linearization extended to 870MHz is available with fixed output levels of 2, 4, 6, 8, 10, 12, 13, 14, and 15dBm. The 1GHz linearized transmitter helps MSOs unlock narrowcast bandwidth as subscribers demand advanced services and new content. Extended bandwidth from 870MHz to 1GHz will enable broadband service providers to increase forward capacity by 16% and the digital spectrum by 40%.

Energy efficient internal components and effective thermal design keep lasers cool to ensure effective, reliable performance. These versions offer hot-swappable and integrated management through the local Craft GUI and remote management via SNMP HMS-compliant interface for external connections to an element manager.

The full featured, 1GHz dual-input transmitter offers multiple levels of drive control providing maximum flexibility addressing a broad range of applications. The Dual input capability presents 60dB of isolation from 45 to 870MHz, superior to alternative offerings. The dual input forward transmitter's high performance isolation offers, for example, simultaneous advanced service deployment of video and telephony without cross talking impairment. Integral high isolation eliminates having to add external devices to achieve similar performance, thereby lowering capital expenditures and reducing complexity.

Up to 10 CHP Max5000 transmitters can reside in the standard 2 RU CHP Max5000 chassis, with RF input and optical bulkhead connector access from the rear panel. Thus, a standard 40RU rack holds up to 200 CHP Max5000 1GHz Extended Linearized Forward Transmitters, providing exceptional space efficiency and reducing operational costs.

Features

- 1 GHz technology
- Unlock narrowcast bandwidth to accelerate deployment of advanced services
- Investment protection through high module density (10 modules in a 2RU footprint)
- Dual high isolation full-bandwidth inputs for simultaneous advanced service deployment of video and telephony without cross-talk impairments
- Fixed output transmitters with 2, 4, 6, 8, 10, 12, 13, 14, and 15 dBm output
- GUI configurable automatic drive control (ADC)
- Universal local or remote management through Craft interface and SNMP with HMS
- Economical fixed output version of the variable output series transmitter
- Downloadable firmware upgrades

Applications

1 GHz Forward GFX-DXL TX Functional Block Diagram

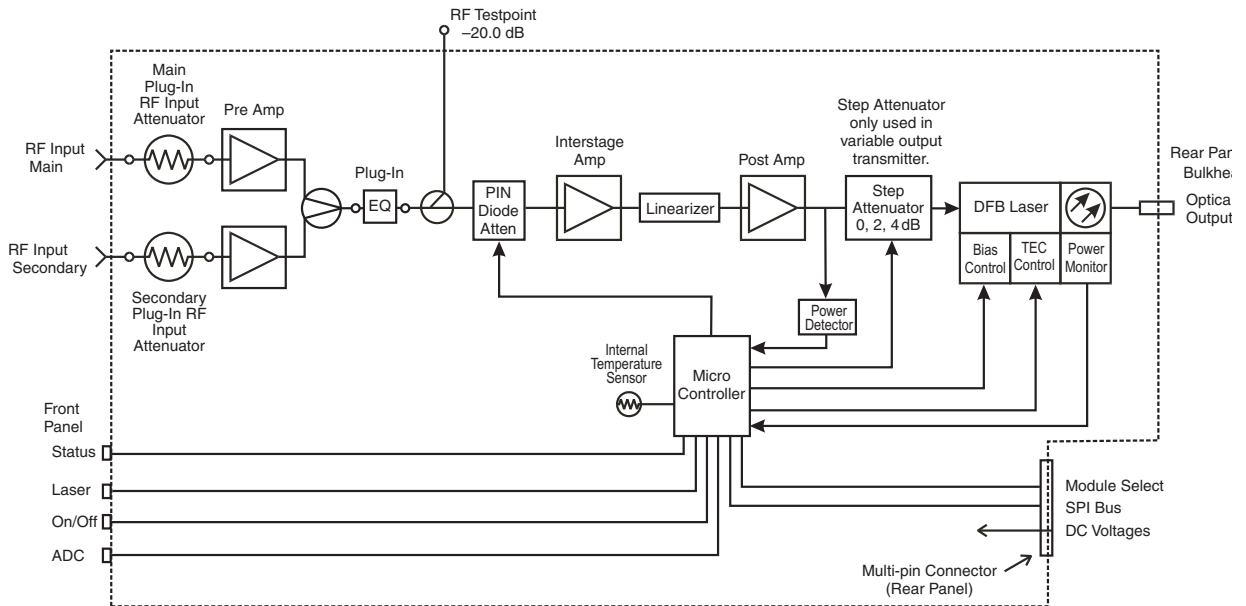

CHP-GFX-DXL Specifications

Optical	
Optical Wavelength	1310nm ± 10nm
Optical Output Power	2, 4, 6, 8, 10, 12, 13, 14, 15 dBm
RF	
Bandwidth Frequency Range, MHz	45 to 1002
Response Flatness, typ., dB	±0.5
Input Return Loss, minimum, dB	16
Port-to-Port Isolation	
45 to 870MHz, dB	>60
870 to 1002MHz, dB	>50
ADC Range, dB	±3.0
Powering	
Power Consumption (maximum), W	17.4
Performance	
Channel Plan	128 NTSC Channels
Input RF Power, Analog Channels, dBmV/ch	13
Composite Second Order, dBc	-63
Composite Triple Beat, dBc	-68
Mechanical	
Optical Connector	SC/APC
RF Connector	F-Type
RF Input Testpoint, dB	-20 ± 1.0
Dimensions (W x H x D), in/cm	1.25 x 3.4 x 18.5/3.2 x 8.7 x 47.0
Weight, lbs/kg	2.75/1.24
Environmental	
Operational Temperature (storage), °F/°C	32 to 122/0 to 50 (-40 to 158/-40 to 70)
Humidity, noncondensing (storage), max.	85%
Storage Humidity, noncondensing, max.	95%

Specifications subject to change without notice

NTSC CNR Performance

	CHP-GFX-DXL-								
	02	04	06	08	10	12	13	14	15
Output Power (dBm)	2.0	4.0	6.0	8.0	10.0	12.0	13.0	14.0	15.0
Fiber Length (km)	2.8	8.3	13.8	15.0	15.0	20.0	20.0	20.0	20.0
Optical Loss Budget (dB)	CNR (dB) for part fiber/part passive link (typical)								
2	51.5	—	—	—	—	—	—	—	—
3	50.8	51.8	—	—	—	—	—	—	—
4	50.0	51.1	—	—	—	—	—	—	—
5	—	50.4	51.0	—	—	—	—	—	—
6	—	49.5	50.5	—	—	—	—	—	—
7	—	—	49.8	51.1	—	—	—	—	—
8	—	—	49.0	50.4	—	—	—	—	—
9	—	—	—	49.8	51.1	—	—	—	—
10	—	—	—	49.2	50.4	—	—	—	—
11	—	—	—	—	49.8	51.1	—	—	—
12	—	—	—	—	49.2	50.4	51.1	—	—
13	—	—	—	—	—	49.8	50.4	51.1	—
14	—	—	—	—	—	49.2	49.8	50.4	51.1
15	—	—	—	—	—	—	49.2	49.8	50.4
16	—	—	—	—	—	—	—	49.2	49.8
17	—	—	—	—	—	—	—	—	49.2

Specifications subject to change without notice

C-COR™ CHP Max5000 1 GHz Extended Linearized Forward Transmitters

CENELEC CNR Performance

	CHP-GFX-DXL-								
	02	04	06	08	10	12	13	14	15
Output Power (dBm)	2.0	4.0	6.0	8.0	10.0	12.0	13.0	14.0	15.0
Fiber Length (km)	2.8	8.3	13.8	15.0	15.0	20.0	20.0	20.0	20.0
Optical Loss Budget (dB)	CNR (dB) for part fiber/part passive link (typical)								
2	55.1	—	—	—	—	—	—	—	—
3	54.4	55.4	—	—	—	—	—	—	—
4	53.6	54.7	—	—	—	—	—	—	—
5	—	54.0	54.6	—	—	—	—	—	—
6	—	53.1	54.1	—	—	—	—	—	—
7	—	—	53.4	54.7	—	—	—	—	—
8	—	—	52.6	54.0	—	—	—	—	—
9	—	—	—	53.4	54.7	—	—	—	—
10	—	—	—	52.8	54.0	—	—	—	—
11	—	—	—	—	53.4	54.7	—	—	—
12	—	—	—	—	52.8	54.0	54.7	—	—
13	—	—	—	—	—	53.4	54.0	54.7	—
14	—	—	—	—	—	52.8	53.4	54.0	54.7
15	—	—	—	—	—	—	52.8	53.4	54.0
16	—	—	—	—	—	—	—	52.8	53.4
17	—	—	—	—	—	—	—	—	52.8

Note:

1. Estimated.

Specifications are subject to change without notice

Ordering Information

				1	2	3			4	5	6			7	8		9
C	H	P	-	G	F	X	-	D	X	L	-	x	x	-	S		

1-3 Forward Transmitter Type	GFX 1310nm fixed output transmitter series
4 Transmitter Inputs	D Dual Input
5-6 Transmitter Linearization	XL 870MHz Linearization
7-8 Optical Output Level	02 Fixed optical output power of 2 dBm 04 Fixed optical output power of 4 dBm 06 Fixed optical output power of 6 dBm 08 Fixed optical output power of 8 dBm 10 Fixed optical output power of 10 dBm 12 Fixed optical output power of 12 dBm 13 Fixed optical output power of 13 dBm 14 Fixed optical output power of 14 dBm 15 Fixed optical output power of 15 dBm
9 Connector Type	S SC/APC



The capabilities, system requirements and/or compatibility with third-party products described herein are subject to change without notice. ARRIS, the ARRIS logo, C3™, C4™, CableEdge®, Cadant®, C-COR®, CHP Max®, Cornerstone®, CXM™, D5™, Digicon®, Flex Max®, Keystone™, MONARCH™, n5™, nABLE™, NSM™, nVision™, PLEXIS™, Regal™, ServAssure™, TeleWire Supply™, Touchstone®, VoiceAssure™, and WorkAssure™ are all trademarks of ARRIS Group, Inc. Other trademarks and trade names may be used in this document to refer to either the entities claiming the marks and the names of their products. ARRIS disclaims proprietary interest in the marks and names of others. © Copyright 2008 ARRIS Group, Inc. All rights reserved. Reproduction in any manner whatsoever without the express written permission of ARRIS Group, Inc. is strictly forbidden. For more information, contact ARRIS.

CHPGFXDXL--AT-D-0408

