



# 1GHz Redundant Forward Receivers

## CHP-GFRX

### C-COR® CHP Max5000

- 1GHz technology
- Up To 10 receiver channels per chassis
- Up to 200 receiver channels per rack
- Optional optical path resiliency and hardware redundancy
- Hot-swappable
- Local Craft and remote SNMP monitoring
- High RF output



ARRIS C-COR CHP Max5000 1GHz Redundant Forward Receivers, designed to accept an optical forward path signal from a CHP Forward Path Transmitter, are an integral part of the CHP Max5000 platform, which converges headend, hub, and digital transport onto one 2RU scalable system allowing service providers to accelerate deployment of advanced services such as video on demand, high speed data, and telephony. Extending bandwidth from 870MHz to 1GHz will enable broadband service providers to increase the overall forward capacity by 16% and the digital spectrum by 40%.

The CHP Max5000 1GHz Redundant Forward Receiver can operate as either a stand-alone receiver or can be configured as a redundant receiver with the addition of a second module and a Redundant Communications Link Cable (RCL2), providing optical path resiliency and hardware redundancy to maintain uninterrupted service availability in the event of optical path or hardware failure. Automatic switchover time for optical path or hardware failure is less than or equal to 50ms. The CHP Max5000 platform offers operators the flexibility to set the optical input and RF output thresholds for switching to the redundant module. Redundant modules may be located in the same CHP chassis or in a different rack located within the maximum RCL2 length of 6 meters (20 feet). A major alarm is generated if either the optical input power or RF output power exceeds a user-defined major high limit or drops below a user-defined major low limit.

The CHP Max5000 1GHz Redundant Forward Receiver is designed for both 1310nm and 1550nm network architectures with an input power range from -10 to 4dBm. It provides a high RF output up to 1002MHz with a noise contribution of less than  $8\text{pA/Hz}^{0.5}$  eliminating the need for additional RF amplification when combining many circuits.

The front panel has module and channel status LEDs, and up and down gain adjustment buttons, which can be locked out by the local Craft Management Graphical User Interface for security purposes.

## Features

- Exceptional price/performance ratio
- Stand-alone or redundant operation with the use of a redundant communications link cable
- Up to 10 receivers per chassis and 200 receivers per rack for high density and reduced heating, cooling, and power costs
- Optical input range of -10 to 4 dBm at the receiver
- Extending bandwidth from 870 MHz to 1 GHz increases overall forward capacity by 16% and the digital spectrum by 40%
- RF output level adjustment per channel via front-panel pushbutton or via CMM or SMM
- High RF output of 41 dBmV/channel with 0 dBm input reduces the need for an external RF amplifier
- Front-panel RF testpoint for convenient monitoring
- Local or remote monitoring
- Downloadable firmware upgrades

## Functional Block Diagram

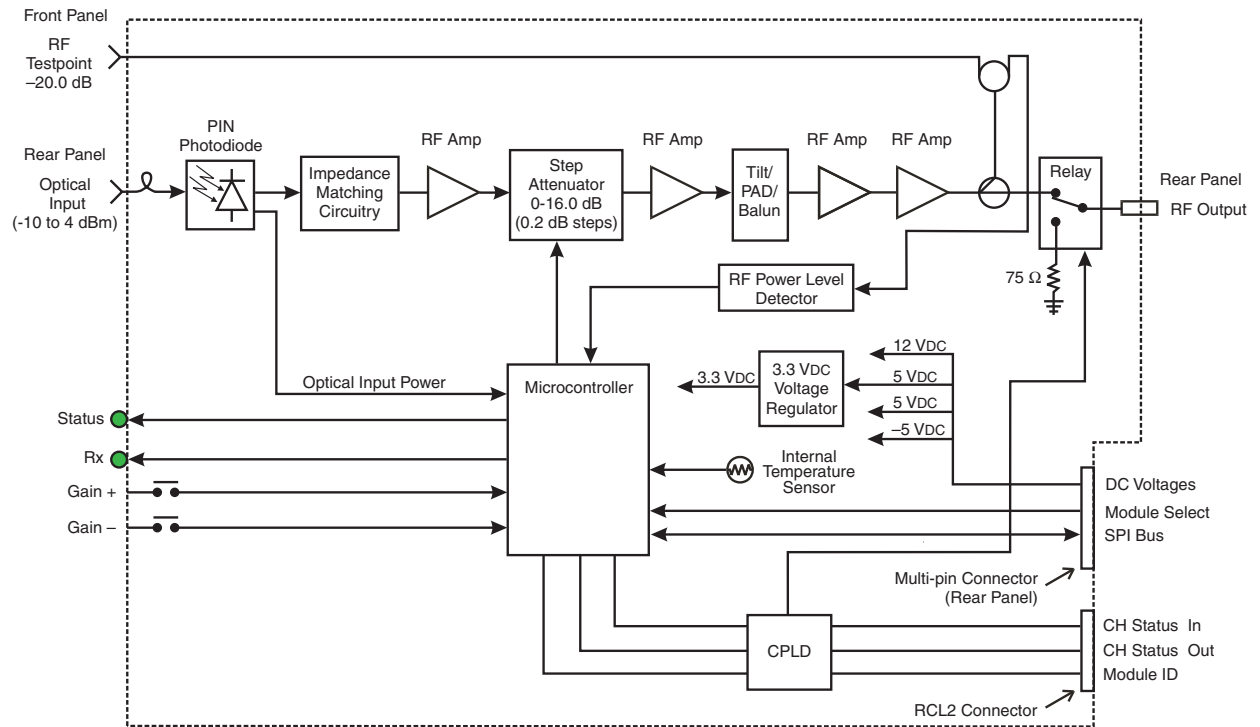

## Specifications

<b>Optical Specifications</b>			
Input Wavelength Range	1200 to 1620 nm		
Optical Input Power Range <sup>1</sup>	-10 to 4 dBm		
Optical Testpoint Monitor	1.0 ± 10% mW/V		
<b>RF Specifications</b>			
RF Output Bandwidth	42 to 1002 MHz		
RF Output Power Level <sup>2,3</sup>	41 dBmV/channel		
Output Return Loss	≥ 16 dB		
Flatness, peak-to-valley	±0.75 dB with respect to gain slope		
Gain Slope	±1.0 dB		
RF Gain Adjustment Range	0 to 16 in 0.2 dB steps		
RF Output Stability	±1.0 dB referenced at 25°C		
RF Output Testpoint	-20 ± 0.5 dB		
<b>Performance Specifications</b>			
Equivalent Input Noise	< 8 pA/Hz <sup>0.5</sup>		
Optical Input to RF Output Isolation	≥ 70 dBc		
Spurious Signals	≤ -65 dBc		
Redundant Switching Time	≤ 50 ms		
GFRX Distortion Contribution <sup>4</sup>	Broadband <sup>5,6</sup>	Broadband <sup>5,6</sup>	Splitband <sup>6,7</sup>
Optical Input/RF Rx Output Level	-3 to 0 dBm/≤38 dBmV	0 to 3 dBm/≤41 dBmV	-3 to 3 dBm/≤41 dBmV
CTB	< -85 dBc	< -78 dBc	< -85 dBc
CSO	< -69 dBc	< -64 dBc	< -65 dBc
CIN <sup>8</sup>	>75 dB	>62 dB	—
CNR	TX spec plus Equivalent Input Noise (EIN) contribution. CNR increases or decreases proportionally over an optical input range of -3 to 3 dBm.		
<b>Power Specifications</b>			
Power Consumption, max.	10.5 Watts		
<b>Mechanical Specifications</b>			
Dimensions (W x H x D)	1.25 x 3.4 x 18.5 in. (3.2 x 8.7 x 47.0 cm)		
<b>Environmental Specifications</b>			
Operating Temperature	0 to 50°C (32 to 122°F)		
Operating Humidity, noncondensing	10 to 90%		

1. Typical optical input power operating range is -3 to 3 dBm.
2. RF output level is 41 dBmV per channel at 0 dBm optical input and 3.9% OMI. Maximum RF output level for system use is 41 dBmV/channel. Do not exceed 41 dBmV/channel RF output level from the GFRX.
3. Graph shows minimum forward receiver output level for the stated transmitter optical modulation index per channel, with receiver optical input set to +3 dBm and internal attenuator set to 0 dBm. To determine RF output levels at other optical input power levels, subtract (or add) 2 dB of RF level for every decrease (or increase) of 1 dB in optical input power.
4. Performance listed indicates "receiver only" non-linear distortion performance. This performance is back calculated using transmitter specifications and actual performance to a reference optical receiver, in conjunction with the GFRX.
5. 79 NTSC channels loaded from 55 to 550 MHz plus 450 MHz simulated digital loading from 550 to 1002 MHz at -6 dBc below equivalent analog channels.
6. Reference transmitter used for 79 NTSC + 450 MHz digital loading is CHP-GFXV series. Reference transmitter used for 40 Analog NTSC loading is CHP-XMOD MU/ML series.
7. 40 NTSC loading occupying lower or upper frequency spectrum in the 55 to 550 MHz range.
8. CIN: Composite Intermodulation Noise. Defined as the ratio of the carrier to the noise-like signals generated by the non-linearity of a broadband transmission system carrying a combination of analog and digital signals. These distortion products are analogous to the CSO and CTB products generated by the analog carriers, but due to the pseudo-random nature of the digital modulation signals, appear as noise like interference. Reference test procedure ANSI/SCTE 17 2001 (Test procedure for Carrier to Noise) for CIN measurement standards.

Specifications subject to change without notice

# C-COR™ CHP Max5000 1 GHz Redundant Forward Receivers

## GFRX Output Level versus Optical Modulation Index (OMI)

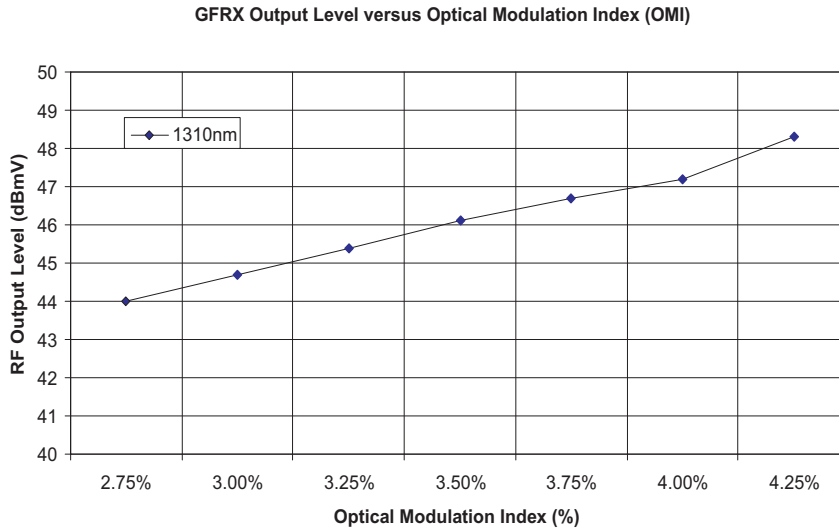

## Ordering Information

### Redundant 1 GHz Forward Receiver

				<b>1</b>	<b>2</b>	<b>3</b>	<b>4</b>		<b>5</b>
<b>C</b>	<b>H</b>	<b>P</b>	<b>-</b>	<b>G</b>	<b>F</b>	<b>R</b>	<b>X</b>	<b>-</b>	<b>S</b>

<b>1-4</b>	<b>Module Type</b>
GFRX	Redundant 1 GHz forward receiver

<b>5</b>	<b>Connector Type</b>
S	SC/APC

Note: The Redundant Communications Link Cable (P/N CHP-RCL2-xx) is required when configuring a CHP forward path receiver as a redundant receiver with the addition of a second receiver module.

### Redundancy Cable

								<b>1</b>	<b>2</b>	
<b>C</b>	<b>H</b>	<b>P</b>	<b>-</b>	<b>R</b>	<b>C</b>	<b>L</b>	<b>2</b>	<b>-</b>	<b>x</b>	<b>x</b>

<b>1-2</b>	<b>Length of Redundancy Cable</b>	
E0	Two inch redundancy cable	a
01	One foot redundancy cable	
05	Five foot redundancy cable	
10	Ten foot redundancy cable	
20	Twenty foot redundancy cable	
a) European installations must only use the CHP-RCL2-E0 redundant cable		

See the CHP Max5000 Converged Headend Platform data sheet for additional ordering information.



The capabilities, system requirements and/or compatibility with third-party products described herein are subject to change without notice. ARRIS, the ARRIS logo, C3™, C4™, CableEdge®, Cadant®, C-COR®, CHP Max®, Cornerstone®, CXM™, D5™, Digicon®, Flex Max®, Keystone™, MONARCH™, n5™, nABLE™, NSM®, nVision®, PLEXIS®, Regal®, ServAssure™, TeleWire Supply®, Touchstone®, VoiceAssure™, and WorkAssure™ are all trademarks of ARRIS Group, Inc. Other trademarks and trade names may be used in this document to refer to either the entities claiming the marks and the names of their products. ARRIS disclaims proprietary interest in the marks and names of others. © Copyright 2008 ARRIS Group, Inc. All rights reserved. Reproduction in any manner whatsoever without the express written permission of ARRIS Group, Inc. is strictly forbidden. For more information, contact ARRIS.

CHPGFRX--D-0608

