



1 GHz Externally Modulated Transmitter

CHP-GMOD

C-COR® CHP Max5000



- 1GHz bandwidth increasing forward capacity by 16%
- Transmitter series offers intermediate (65 km) and long (100km) range performance models
- Simplified installation and control with graphical user interface
- Universal management through Craft interface and SNMP with HMS

CHP Max5000 1GHz Externally Modulated Transmitters help MSOs unlock narrowcast bandwidth as subscribers demand advanced services and offer scalable long distance optical solutions. Extended bandwidth from 870MHz to 1GHz will enable broadband service providers to increase forward capacity by 16% and the digital spectrum by 40%. These dual output CHP Max5000 1550nm transmitters are designed for use with CHP EDFA series modules, simplifying applications by providing low noise, integrated element management capability, reduced rack space, and power requirements at geographical reach distances of up to 100km—the preferred solution for HFC or FTTx applications.

Advanced adjustable SBS from 12 to 18dB provides the flexibility to optimize link performance with minimal inventory providing both CapEx and OpEx savings. The existing performance range option provides a 65km geographical reach. Laser options enable 1555 ± 5 nm for WDM, 1545 ± 1 nm for Red/Blue, and 1550 ITU for DWDM applications providing a variety of solutions for fiber challenged long distance applications.

The 2RU CHP Max5000 chassis can accommodate up to 5 double-width externally modulated transmitter modules (up to 100 double-width modules in one standard 40RU rack) to relieve the pressure on precious headend space as you expand your network offering advanced service applications.

CHP Max5000 1GHz Externally Modulated Transmitters offer hot-swapping and integrated monitoring and configuration control through a Craft graphical user interface with local or remote access. Remote management is accessible through the SNMP HMS-compliant interface for external connection to an element manager. Energy efficient internal components and effective thermal design keep optical components cool to ensure effective, reliable performance.

Features

- Advanced 1 GHz technology and adjustable SBS from 12 to 18 dB for maximum performance and minimal inventory
- Laser options support standard 1555 +/- 5 nm, 1545 +/- 1 nm, and DWDM for various fiber challenged applications
- High-density solution (up to 5 modules per 2RU chassis and 100 modules per 40RU rack)

Applications

65 km Single Channel Application

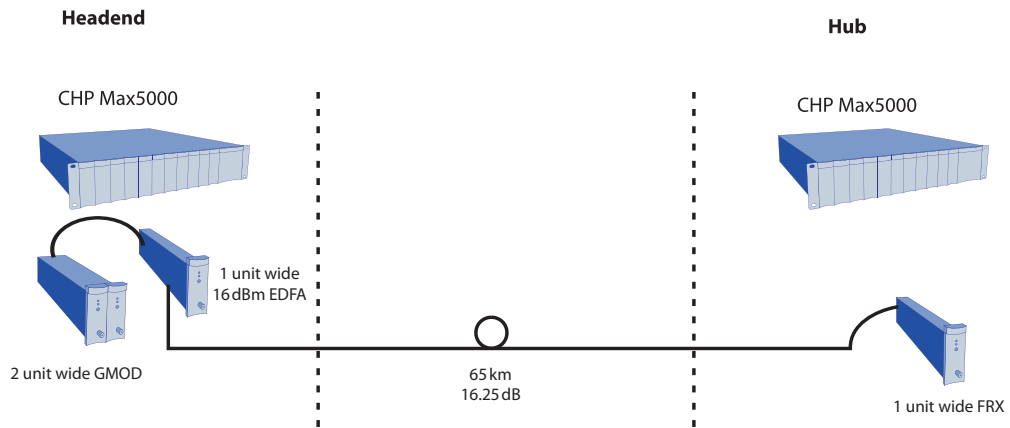

65 km Split Channel Application

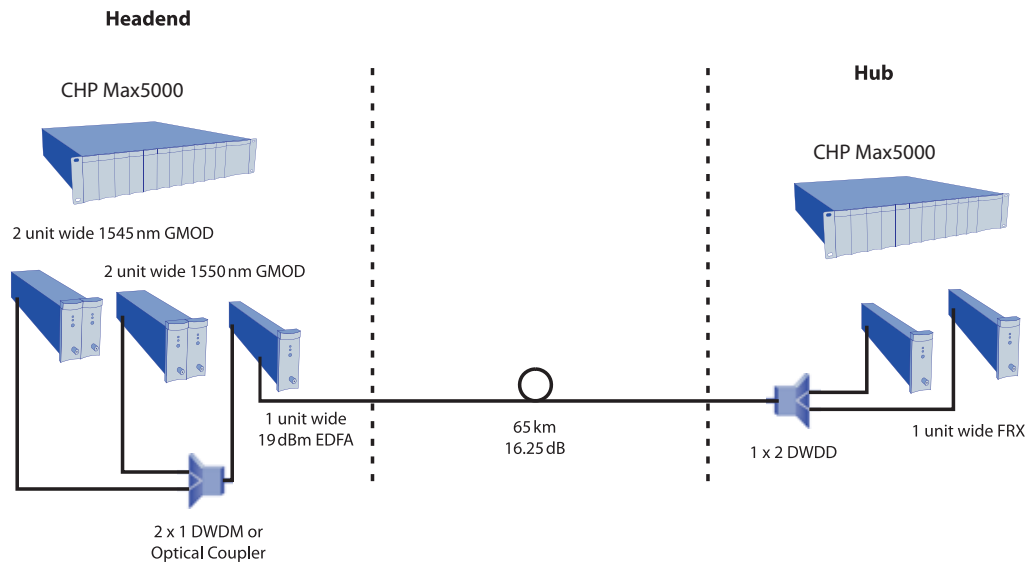

Note: Refer to the CHP Max5000 EDFA data sheet for 100km Single and Split Channel application diagrams.

Specifications

RF Specifications

RF Bandwidth	40 to 1002 MHz
RF Input Power	39 ± 3 dBmV total power 23 dBmV/channel @ 40 NTSC channels 20 dBmV/channel @ 80 NTSC channels 18.5 dBmV/channel @ 112 NTSC channels
Flatness	±0.5 dB, max. 40 to 870 MHz; ±0.75 dB, max. 40 to 1002 MHz without EDC ±0.5 dB, 40 to 550 MHz; ±0.75 dB, 40 to 1002 MHz with EDC
Impedance	75 Ohm
Return Loss	17 dB, min., all ports (40 to 870 MHz, 16 dB min, all ports 870 to 1002 MHz)
Residual Spurs	< 65 dBc
Number of Inputs	1

Common Optical Specifications

Wavelength	1545 ± 1 nm; 1555 ± 5 nm; odd ITU channels 21 through 29, 39
Line Width	0.6 MHz, max.
Optical Output Power, Ports 1 and 2	8 dBm
Laser RIN	< -157 dBc/Hz
Optical Return Loss	> 55 dB
Optical Modulation Index	3% min. per channel/80 channels
SBS Suppression	Variable 12 dB to 18 dB
Number of Outputs	2

Medium Haul Performance Specifications (Note 1)	80/112 NTSC Channel Loading + 300 MHz QAM to 870 MHz (450 MHz QAM to 1002 MHz) (Notes 2, 3, 5, and 6)		Split Band 40 Low/40 High NTSC Ch. for 40 NTSC + 300 MHz QAM to 870 MHz (450 MHz QAM to 1002 MHz) (Notes 2, 3, 7)		Split Band 60 Low/20 High NTSC Ch. for 60 NTSC + 450 MHz QAM to 1002 MHz (Notes 2, 4, 8)	
Link Budget	65 km		65 km		50 km	
	80 channels	112 channels	40 channel low	40 channel high	60 channel low	20 channel high
CNR	52.5 (51.5) dB	51 (50) dB	55.2 (54) dB	55.2 (54) dB	54.5 dB	54.5 dB
CTB	-66 dBc	-66 dBc	-70 dBc	-70 dBc	-68 dBc	-68 dBc
CSO	-66 dBc	-66 dBc	-70 dBc	-70 dBc	-69 dBc	-69 dBc
XMOD	-66 dBc, max.	-66 dBc, max.	-70 dBc, max.	-70 dBc, max.	-70 dBc, max.	-70 dBc, max.

Long Haul Performance Specifications (Note 1)	80/112 NTSC Channel Loading + 300 MHz QAM to 870 MHz (450 MHz QAM to 1002 MHz) (Notes 2, 3, 5, and 9)		Split Band 40 Low/40 High NTSC Ch. for 40 NTSC + 300 MHz QAM to 870 MHz (450 MHz QAM to 1002 MHz) (Notes 2, 3, 10)		Split Band 60 Low/20 High NTSC Ch. for 60 NTSC + 300 MHz QAM to 870 MHz (450 MHz QAM to 1002 MHz) (Notes 2, 4, 11)	
Link Budget	100 km		100 km		90 km	
	80 channels	112 channels	40 channel low	40 channel high	60 channel low	20 channel high
CNR	49.8 (48.8) dB	47.5 (46.5) dB	52.3 (51.3) dB	52.3 (51.3) dB	52.5 (51.5) dB	52.5 (51.5) dB
CTB	-66 dBc	-65 dBc	-70 dBc	-70 dBc	-68 dBc	-68 dBc
CSO	-65 dBc (with EDC)	-65 dBc (with EDC)	-70 dBc	-70 dBc	-69 dBc	-69 dBc
XMOD	-66 dBc, max.	-66 dBc, max.	-70 dBc, max.	-70 dBc, max.	-70 dBc, max.	-70 dBc, max.

Powering

Power Consumption	40 W, max.; 12 V at 1.6 A, max.
-------------------	---------------------------------

