



Trans Max™

Trans Max4100 RFoG Repeater



More Customers, More Reach

- Supports RFoG architectures beyond 20km with optical amplification

More Revenue in Less Time

- Repeater can be segmented for smaller service groups and higher capacity per subscriber in conjunction with the CORWave™ II multi-wavelength transmitters
- Segmentation can be facilitated with a simple firmware download—no truck roll required

Lowered OPEX

- Parts commonality with the Opti Max4100 optical node reduces sparing and inventory SKUs
- Allows easy field conversion from an Opti Max4100 node to a Trans Max4100 RFoG repeater configuration

Synchronizing critical new elements into a cable operator's already deployed network ensures that the cable operator's capital investment can scale with subscriber growth or marketing initiatives seamlessly, cost-effectively and quickly.

Reach More Customers with Longer Fiber Links

The Trans Max4100 RFoG repeater is an essential part of an RFoG fiber network that optically amplifies signals for service groups located beyond traditional HFC networks, all-fiber networks, or less densely populated areas where feeder fiber may be limited. In the downstream, it amplifies the optical signals to reach beyond 20km from the headend. It can operate on as little as a single transport fiber and provides 8 outputs at 13 or 17dBm each that support 32 RFoG ONUs, for a total capacity of 256 subscribers. In the upstream, it receives, combines and re-transmits the signals back to the headend for further processing, utilizing digital return technology. No special RF accessories are required for set-up of the repeater—configuration and monitoring is done via the craft GUI.

Generate Additional Revenue Through Segmentation Without Truck Roll

By utilizing the CORWave II multi-wavelength transmitters in conjunction with the Trans Max4100, the single service group can be segmented further into 2 groups of 128 each or 4 groups of 64 each to provide targeted content per service group if desired.

If segmentation will be utilized in future as a network upgrade, the Trans Max4100 RFoG repeater can be purchased as a segmented version and set initially for an unsegmented architecture, with the balance of the digital return link channels left inactive. When segmentation is required, the digital return link channels can be activated via a simple firmware download rather than a truck roll, saving deployment time and labor costs.

Lower OPEX with Reduced Inventory SKUs

Commonality with the OM4100 node reduces sparing and inventory SKUs of the housing, power supply modules, return transmitters, EDFA modules and interface board. This commonality also allows conversion from an Opti Max4100 node configuration to a Trans Max4100 RFoG repeater if needed.

Applications

The TransMax4100 RFoG repeater in an unsegmented architecture with 8 ports. Note that both the forward and return can be supported on a single fiber using CORWave II. The repeater in this illustration is preconfigured for segmentation, although the second digital return link channel is inactive at this time.

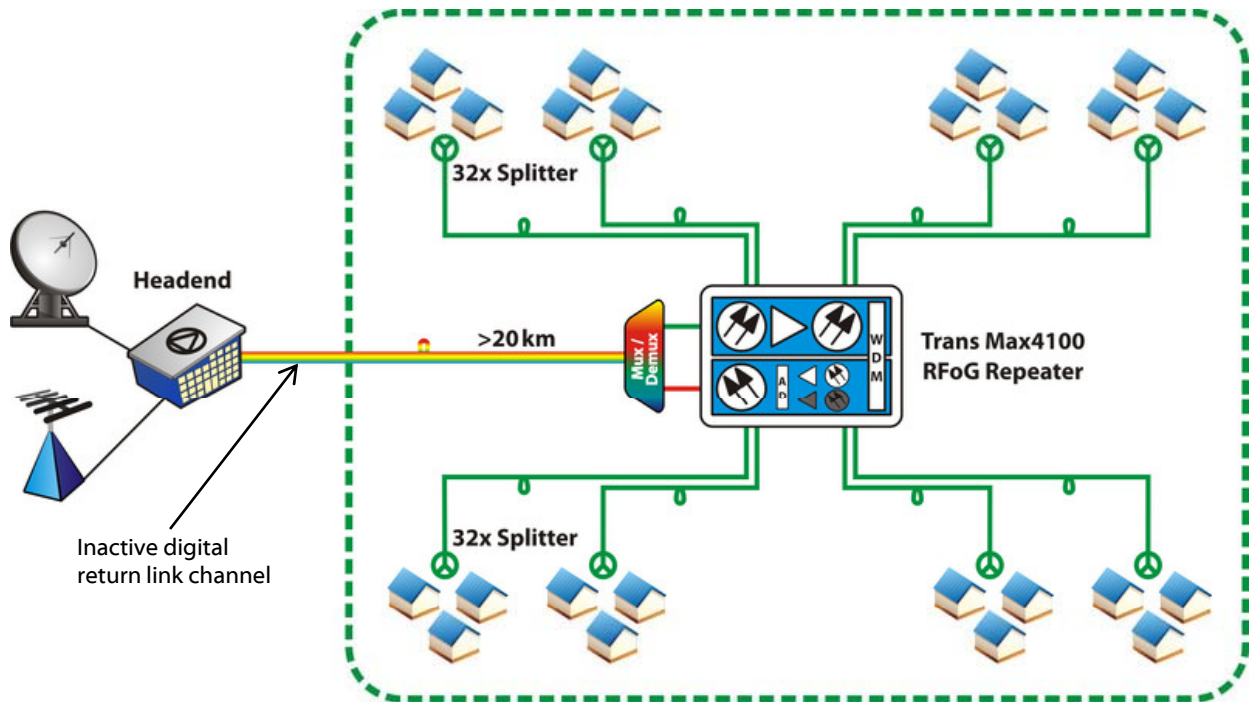

The TransMax4100 RFoG repeater in a 2 x 2 segmented architecture with 8 ports. The second digital return link channel is activated through a firmware download, facilitating segmentation without requiring a truck roll. The system can also be set up to support a 4 x 4 segmentation if desired.

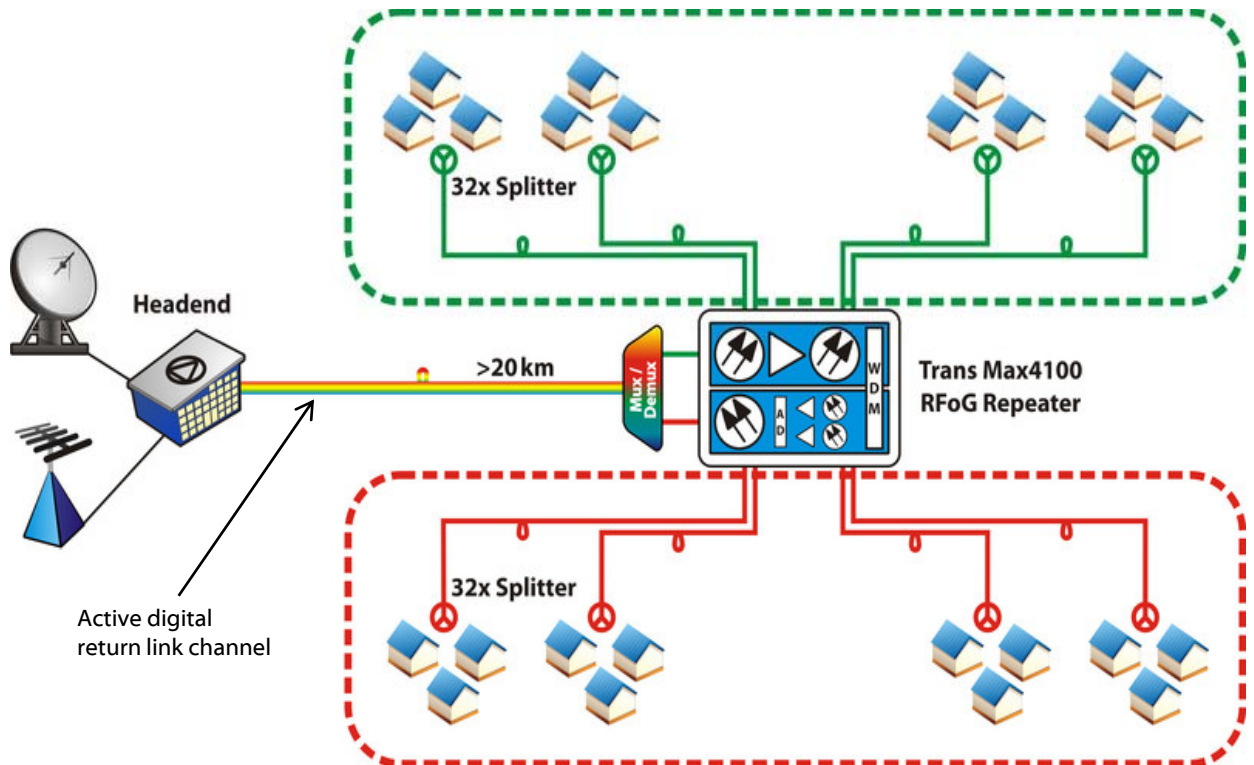

Component Features

- Digital Transmitter—Available in 8-channel CWDM and 45-channel DWDM. Digital transmitters support 2:1 TDM (time division multiplexing) providing double the RF capacity on a single wavelength for reducing service groups by 50%.
- Optical passive modules—Mux/demux passives platforms support a wide range of optical designs and facilitate single fiber transport to and from the headend and the customer premise.
- Quad Path Analog Receivers—Receives up to four separate optical inputs and converts the signal into a single RF output for transport from the ONUs back to the primary or secondary headend via a digital return link.
- Dual redundant load sharing power supplies.
- EMS—Remote monitoring and control of key modules.

ARRIS Solutions

Operators today are constantly challenged to improve their business fundamentals. ARRIS helps enable these improvements through a suite of converged solutions that allows operators to lower capital costs, use existing resources more efficiently, offer new services, and expand into new markets.

ARRIS helps reduce capital costs by consolidating diverse network elements in the data center and headend. This convergence allows efficient, dynamic allocation of network capacity in response to customer demand. Improving the efficiency of optical distribution networks also lowers capital costs and helps operators stay competitive and address new markets such as business services.

ARRIS convergence solutions enable operators to maximize fiber capacity through wavelength efficiencies and multiple architecture options. Subscriber satisfaction and churn are directly related to network reliability. ARRIS delivers a converged suite of network, service and workforce monitoring and management tools that maximize the quality of the customer experience.



TransMax™ —Trans Max4100 RFoG Repeater

Advertising and time-shifted video represent important revenue growth opportunities for operators. ARRIS offers converged video and advanced advertising solutions that enable delivery of content to any device, regardless of where the content is stored and whether the business model is based on subscription, usage, or advertising revenues. Network operators trust our services and solutions because only ARRIS has a history of technology leadership spanning over 50 years. Always at the forefront in standards development and compliance, ARRIS is a valued provider of service offerings that provide a real return on infrastructure investment.

ARRIS solutions for fiber architectures also include the FTMax RFoG ONU, the CORWave multi wavelengths transmitters and digital return receivers and the FTMax EPON OLTs and ONUs. Please contact your ARRIS sales professional for more information on these products.

www.arris.com

Find more information about the Trans Max4100 RFoG Repeater.

- [Product Specifications—Trans Max4100 RFoG Repeater Technical Specifications \(TM4100Repeater_TS_05APR10\)](#)

The capabilities, system requirements and/or compatibility with third-party products described herein are subject to change without notice. ARRIS, the ARRIS logo, Auspice®, C3™, C4®, C4c™, Cadant®, C-COR®, CHP Max™, CHP Max5000™, ConvergeMedia™, Cornerstone®, CORWave™, CXM™, D5®, Digicon®, ENCORE®, Flex Max®, HEMI®, Keystone™, MONARCH®, MOXI®, n5®, nABLE®, nVision®, OpsLogic®, OpsLogic® Service Visibility Portal™, PLEXIS®, PowerSense™, QUARTET®, Regal®, ServAssure™, Service Visibility Portal™, TeleWire Supply®, TLX®, Touchstone®, EGT VIPr®, VoiceAssure™, VSM™, and WorkAssure™ are all trademarks of ARRIS Group, Inc. Other trademarks and trade names may be used in this document to refer to either the entities claiming the marks and the names of their products. ARRIS disclaims proprietary interest in the marks and names of others. © Copyright 2010 ARRIS Group, Inc. All rights reserved. Reproduction in any manner whatsoever without the express written permission of ARRIS Group, Inc. is strictly forbidden. For more information, contact ARRIS.



www.arris.com