

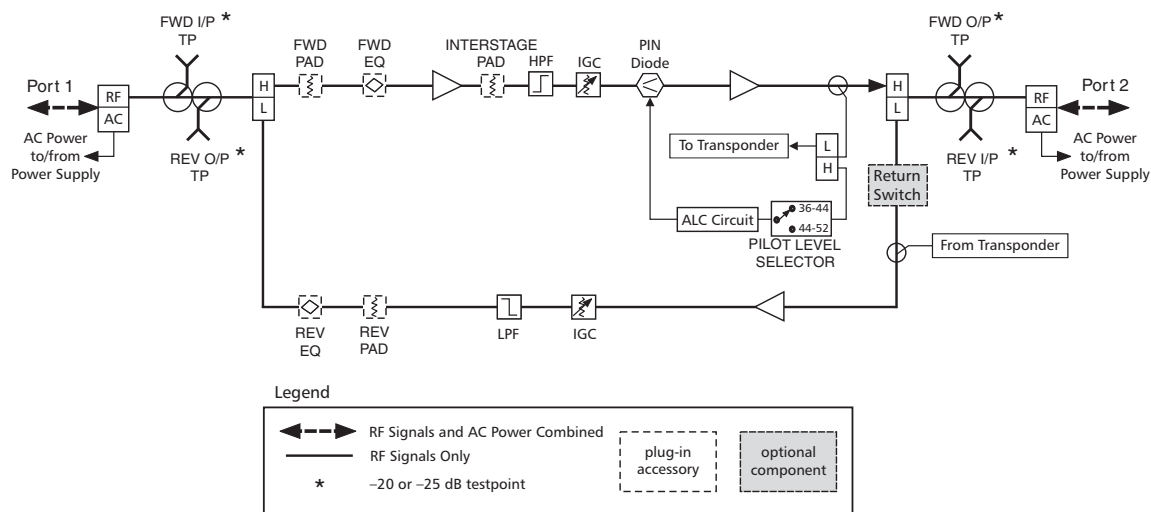

# Flex Max331 1 GHz Multipurpose Line Extender Technical Specification

## Functional Block Diagram for ALC



## Specifications (ALC Version)

	Forward	Return
<b>General</b>		
Bandwidth, MHz	54 to 1002	5 to 42
AC Current Passing, A (Note 1)	15	15
<b>Typical Operating Conditions</b>		
Operational Gain, dB (Note 2)	35	18
Channels, Number of NTSC (Note 3)	79	6
Operating Levels (recommended)		
Frequency, MHz	1002/870/750/550/54	42/5
Input, dBmV, min. (Note 4)	17/15.4/14.4/12.6/10.2	17/17
Output, dBmV (Notes 5, 6)	52/49.5/47.5/44/35	35/35

## Specifications (ALC Version)

### Performance Specifications @ Recommended Levels

(Temperature Range: -40 to 60°C)

#### Carrier-to-Interference Ratio, dB

Composite Triple Beat	77	84
Second Order Beat (F1 ± F2)	—	—
Cross Modulation (per NCTA std.) (Note 7)	72	74
Third Order Beat (F1 ± F2 ± F3)	—	—
Composite 2IM	75	80
Composite Intermodulation Noise (CIN) (Note 8)	73	—
Composite Intermodulation Noise (CIN) (Note 9)	79	—
Noise, 4MHz, 75Ω (Note 10)	68/66.4/65.4/63.6/59.2	70.5
Noise Figure, dB (without EQ) (Note 10)	7/7/7/7/9	5.5
<b>Full Gain, dB (without EQ and ALC)</b>	<b>39.5</b>	<b>19</b>

#### Factory Alignment (with ALC reserve, without EQ)

Cable Loss, dB @ 1002MHz	13	—
Flat Loss, dB	23	19
Gain Slope, dB	-0.25 to 0.75	-0.5 to 0.5
Flatness, dB	±0.5	±0.5
Return Loss, dB, min., all entry ports (Note 11)	16	16

#### Powering Requirements, max./typ. (Note 12)

	With Active Return, EMT, and Return Switch		With Active Return	
	@ 90V	@ 60V	@ 90V	@ 60V
AC Voltage, 60Hz				
AC Power, Watts	26.7/26.1	26.2/25.6	24.9/24.4	24.4/23.9
AC Current, mA	370/355	600/570	340/335	535/520
DC Current, mA @ 24V ± 0.5V	935/915	935/915	870/850	870/850

#### Automatic Level Control

Range, dB @ 1002MHz	+3.5/-4.5	—
Accuracy (-40 to 60°C), dB	±0.5	—
Operating Level Range (from specified levels), dB	±4.5	—
Pilot Frequency Band (recommended), MHz	499.25 (single channel)	—

Specification Document Number 1500171 Rev P

#### Notes:

- AC current passing is shown with factory complete line extenders. AC current passing is 13A for Flex Max331 RF modules used to upgrade E700 series line extenders.
- Spacing is at the highest frequency with SEQ-1G-xx installed. Return spacing includes losses due to housing, diplex filters, and MEQ-42-xx.
- NTSC video channels occupying the appropriate frequency spectrum per specified number of channels.
- Recommended minimum forward input level at 1002MHz including loss due to equalizer.
- Recommended maximum return output level at 42MHz including loss due to equalizer.
- At specified Operational Tilt, maximum Output Level for 1GHz or 870MHz loading is 56.5dBmV@HF.
- Cross modulation specification number indicates typical cascade performance.
- System operating with digitally compressed channels or equivalent broadband noise from 550 to 1002MHz at levels 6dB below equivalent video channels will experience a composite distortion (CIN) appearing as noise in the 54 to 550MHz frequency spectrum.
- System operating with digitally compressed channels or equivalent broadband noise from 550 to 870MHz at levels 6dB below equivalent video channels will experience a composite distortion (CIN) appearing as noise in the 54 to 550MHz frequency spectrum.
- The Noise Figure and C/N specifications are typical within the specified passband.
- Return loss can be degraded by as much as 1.5dB when used with housing option M or N and also when using kit assembly number 1504044-001.
- Power supply is internal to RF module. Refer to drawing #333995-32. For 60VAC powering: AC Power consumption in Watts divided by a factor of 43 = Amps required. For 90VAC powering: For £ 67VAC, 1.03 x (AC power consumption in watts divided by voltage) = Amps required. For 67 - 90VAC, AC power consumption in Watts divided by 65 = Amps required.
- TLC specifications (P/N 1500417) and NLC specifications (P/N 1500519) are also available. Contact your ARRIS sales professional.

Specifications are subject to change without notice

## Ordering Information

To configure a product that meets your specific needs, or for any questions, please contact your ARRIS Sales Professional. You may also use our Product Wizard, located at [support.arrisi.com](http://support.arrisi.com) (User ID and password required). If you do not have a user ID and password or have forgotten your password, please use the Sign In Help section indicated.

---

[www.arrisi.com](http://www.arrisi.com)

The capabilities, system requirements and/or compatibility with third-party products described herein are subject to change without notice. ARRIS, the ARRIS logo, Auspice®, C3™, C4®, C4c™, Cadant®, C-COR®, CHP Max™, CHP Max5000™, ConvergeMedia™, Cornerstone®, CORWave™, CXM™, D5®, Digicon®, ENCORE®, Flex Max®, HEMI®, Keystone™, MONARCH®, MOXI®, n5®, nABLE®, nVision®, OpsLogic®, OpsLogic® Service Visibility Portal™, PLEXIS®, PowerSense™, QUARTET®, Regal®, ServAssure™, Service Visibility Portal™, TeleWire Supply®, TLX®, Touchstone®, EGT VIPr®, VoiceAssure™, VSM™, and WorkAssure™ are all trademarks of ARRIS Group, Inc. Other trademarks and trade names may be used in this document to refer to either the entities claiming the marks and the names of their products. ARRIS disclaims proprietary interest in the marks and names of others. © Copyright 2010 ARRIS Group, Inc. All rights reserved. Reproduction in any manner whatsoever without the express written permission of ARRIS Group, Inc. is strictly forbidden. For more information, contact ARRIS.